

# TOUR LIFT GF 500kg

**VARIABLE SPEED**



**SHOWSDT**  
Scene Design & Technology

# AUTOMATION

# TOUR LIFT GF 500 kg

## SK070-13 C1

### VARIABLE SPEED SERIES

The Tour Lift GF 500 kg is the ultimate variable speed hoist acclaimed for its innovative features and its incredibly flexible handling. The two independent brakes and patented overload system that protects the drive and chain make it the most reliable variable speed hoist on the market.

The Tour Lift GF 500 kg comes with an external box allowing variable speed ranging from 4 ft/min to 40 ft/min. Its smooth start and stop as well as its very quiet operation make it the ideal choice for tours as well as permanent installations like theaters, museums, TV studios and auditoriums. Easy to install, simple to configure and with an ergonomic and compact design, the Tour Lift GF 500 kg has the ability to ramp start, ramp stop, position and vary its speed for maximum artistic effect.

The Standard configuration comes with:

### FEATURES

- Capacity Capacity 500 kg (1102.3 lbs)
- Accurate up to 0.1 mm
- Suspension plate
- Very quiet operation
- Smooth 5 pocket sprocket chain wheel
- Vector controlled acceleration and deceleration
- Dual brake and incremental encoder for safety and precision
- Fully integrated backup system bypassing the controller
- External control box with integrated HMI
- Compatible with BGV C1 standards
- Chain size: 7 mm X 22 mm
- Sold with Drive Brox MK4

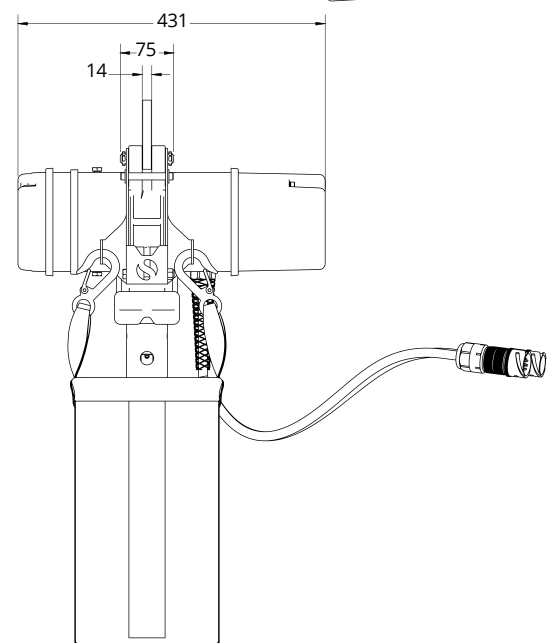
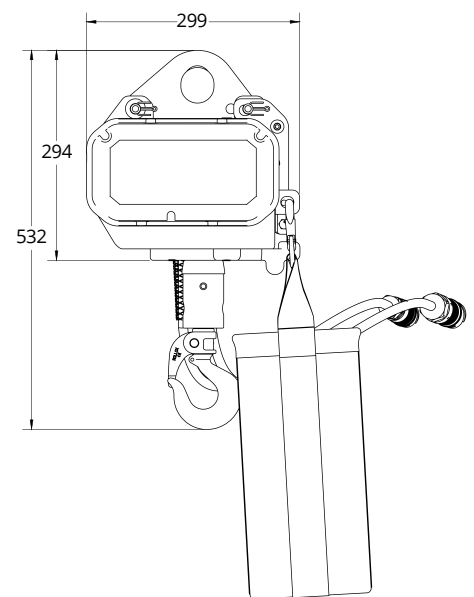

Certified

