

TOUR RIG 1000 kg

DOUBLE BRAKES CHAIN HOIST



SHOWSDT
Scene Design & Technology

CHAIN HOIST

TOUR RIG 1000 kg

DOUBLE BRAKES

FIXED SPEED SERIES: DIRECT CONTROL

The TOUR RIG 1000 kg is the lightest and safest hoist in the industry. Standard features like contactor control, double brakes, overload protection system, and hook suspension will turn your TOUR RIG 1000 kg into your most essential piece of rigging equipment. And options like direct control, 4 channel gear limit switch (external or internal), positioning encoders and eye plate will give you versatility and value for your money.

The TOUR RIG 1000 kg can also be configured in double reeved to reach a capacity of 2000 kg, unleashing twice the lifting capacity at half the speed. Fast and easy set-up.

The Standard configuration comes with:

FEATURES

- Speed range 16 ft/min
- Capacity 1000 kg (2200 lbs) D8 Standard (2000 kg (4400 lbs) in Double Reeved format)
- Jam free plate
- Very quiet operation
- 5 pocket chain wheel for smooth operation
- Lightweight aluminium body
- Friction clutch for overload protection
- Protection IP44
- Road Case Available

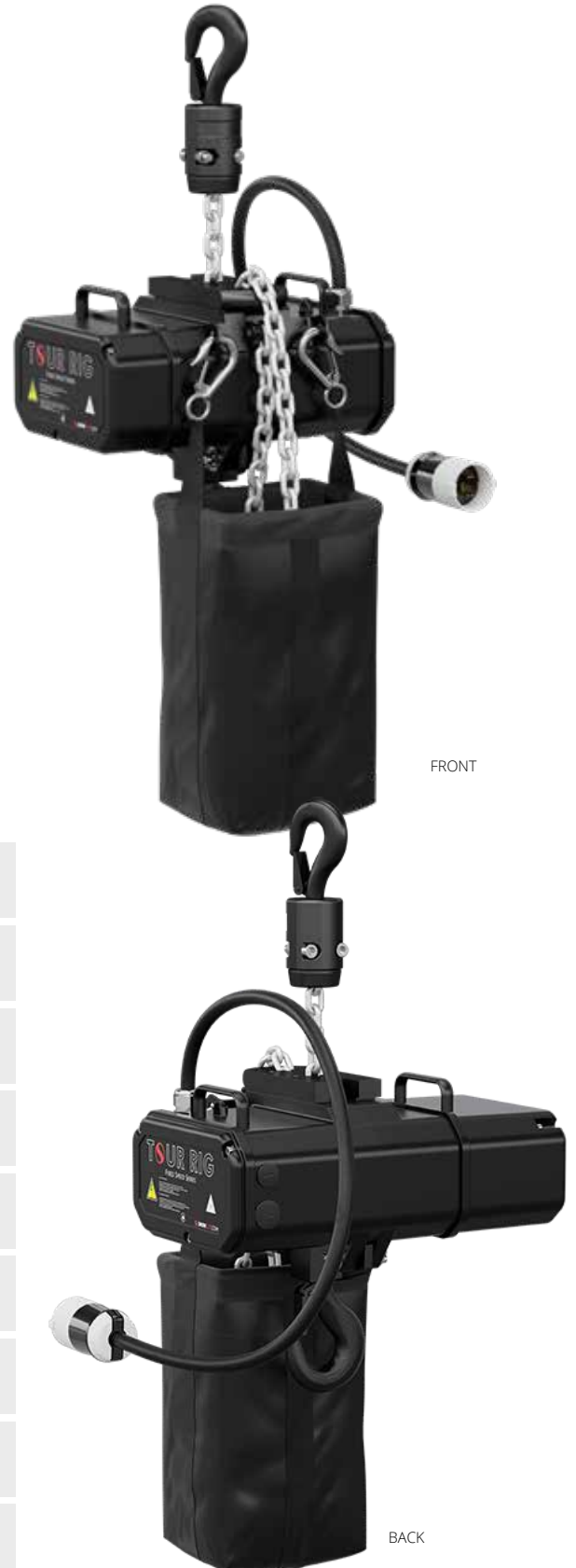

CHAIN HOIST

TOUR RIG 1000 kg

DOUBLE BRAKES

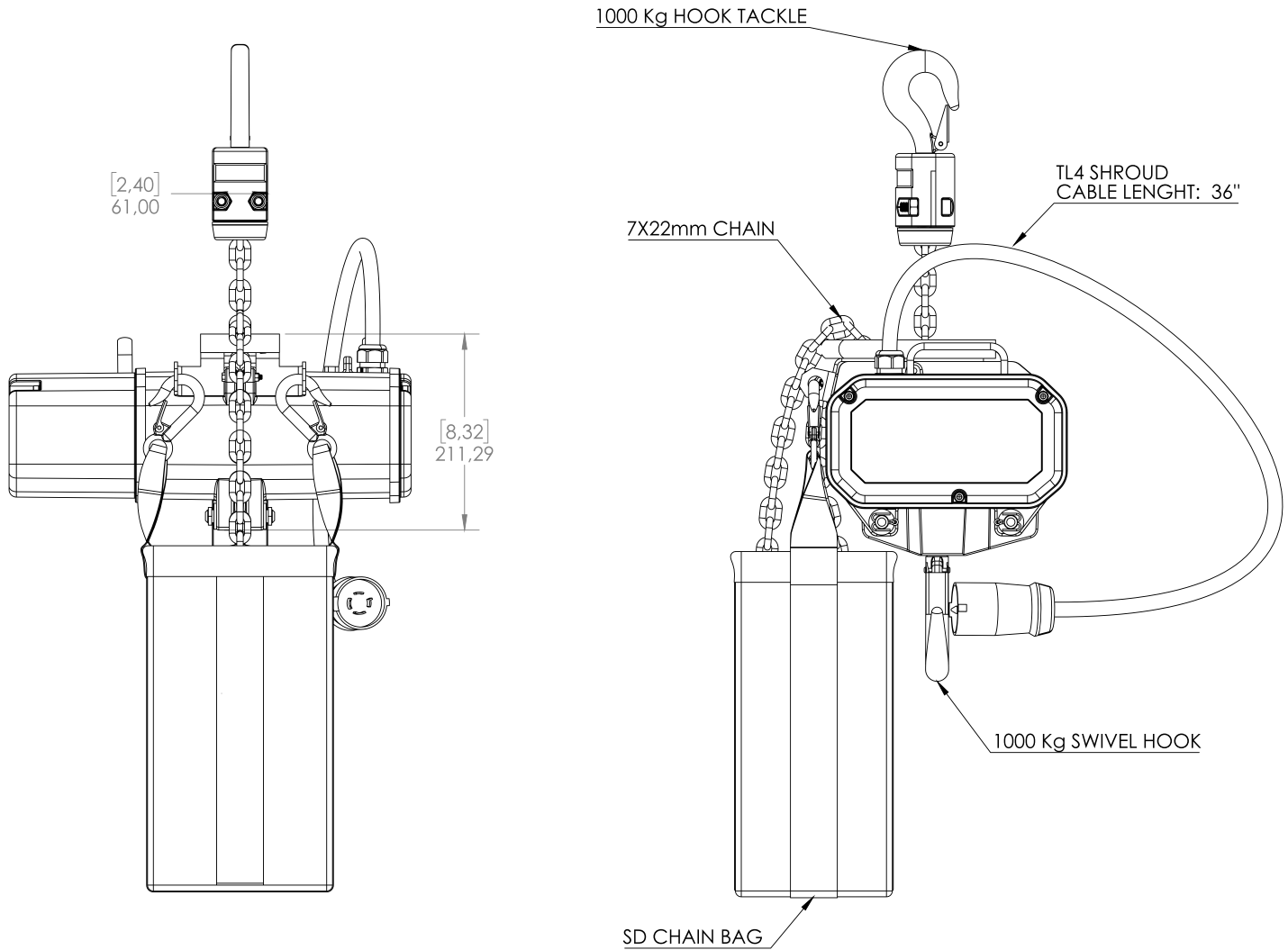

TECHNICAL DATA

● Hoist Model N°	SB4.1/12J-DC	● Control	Direct
● Max Capacity	1000kg	● Motor FLA	5,6A
● Clutch Limit	1400kg	● Chain Size	7 X 22 mm
● Hoist Position	UP/DOWN	● Chain Type	Black/Zinc
● Motor kW/HP	0,75W	● Chain weight/ft	0.74 lbs
● Motor Voltage	208V	● Hoist Body Weight	67 lbs

Certified

