

# TOUR RIG 5000 kg

## CHAIN HOIST



# CHAIN HOIST

## TOUR RIG 5000 kg

### FIXED SPEED SERIES

The TOUR RIG 5000 kg is the lightest and safest hoist in the industry.

Standard features like contactor control, overload protection system, 4 channel gear internal limit switch, hook suspension and double brakes will turn your TOUR RIG 5000 kg into your most essential piece of rigging equipment. And options like positioning encoders, and eye plate will give you versatility and value for your money. Fast and easy set-up.

The Standard configuration comes with:

### FEATURES

- Speed range 16 ft/min
- Capacity 5000 kg (11000 lbs)
- Jam free plate
- Very quiet operation
- 5 pocket chain wheel for smooth operation
- Lightweight aluminium body
- Friction clutch for overload protection
- Chain size 11 X 31 mm
- Protection IP44
- Road case available



# CHAIN HOIST

## TOUR RIG 5000 kg

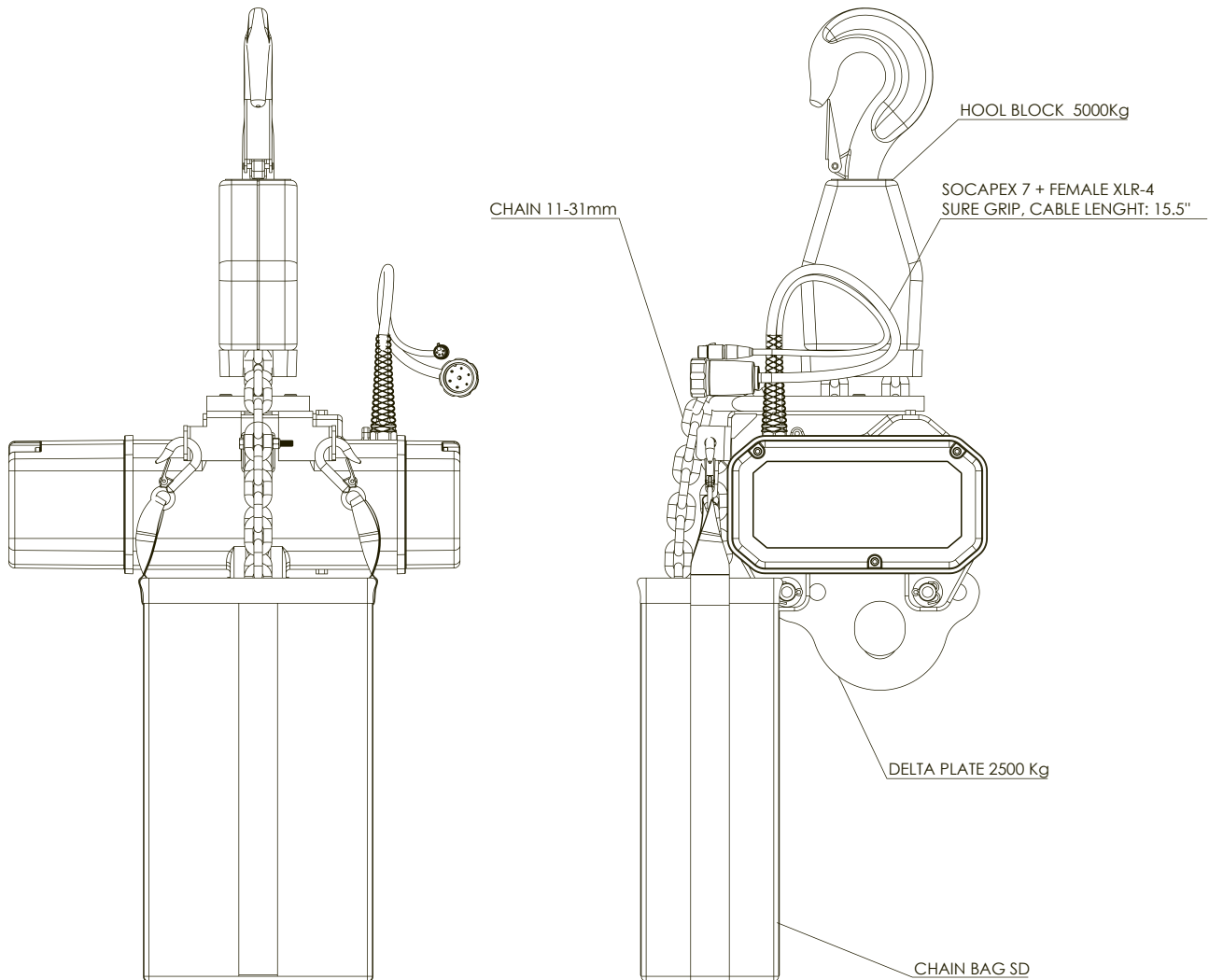

### TECHNICAL DATA

● Hoist Model N°	SB8.3/10V-LV	● Control	24V
● Max Capacity	5000kg	● Motor FLA	14,8A
● Clutch Limit	3300kg	● Chain Size	11 x 31mm
● Hoist Position	UP/DOWN	● Chain Type	Black/Zinc
● Motor kW/HP	3,6kW	● Chain weight/ft	1.82lbs
● Motor Voltage	208V	● Hoist Body Weight	165 lbs

Certified

