

MD5012

STAGE RISERS



SHOWSDT
Scene Design & Technology

STAGE RISER MD5012

The MD5012 has been developed by combining the best features of our most popular risers: Scapin and El Presidente. This combination has created a riser with the highest load-bearing capacity for your events. A multitude of accessories and decors can be attached and secured using unistrut bolts. Ideal for semi-permanent installations and outdoor stages.

ADVANTAGES :

Flexibility: The stage risers are held together with a Dual Lock fastening system to create a uniform surface. Installation is made easy by using a single hexagonal key to tighten the legs and connect the Dual Lock connectors.

Space saver: : Each unit is only 4 inches thick (100 mm) allowing for easy storage in tight spaces. Maximize your storage space with our easy to handle transport and storage trolley.

Durability: Should a Dual Lock fastener, a leg mounting bracket or even an extruded section become damaged, any element can be unbolted from the platform and replaced by a new part without having to change the whole unit.

Modularity: The configuration possibilities are almost limitless. The MD5012 can adapt to all your configuration needs.

Reliability: The simple and solid concept of the MD5012 stage riser is covered by a first rate one-year warranty against manufacturing defects.

The Standard configuration comes with:

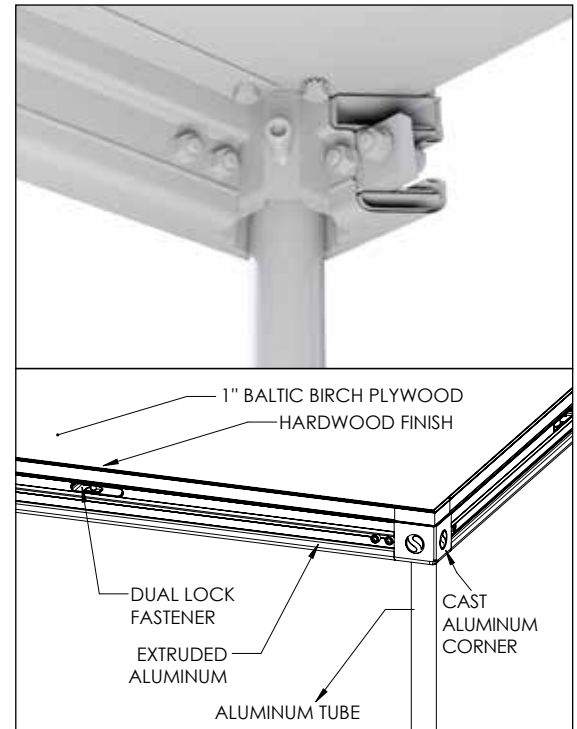

FEATURES

- Extruded aluminum alloy 6061-T6
- Cast aluminum corners A356-T6
- ø1.66" round legs
- 1" Baltic birch plywood
- Distributed load - 250 lb/sq ft (4' X 6' model)
- Concentrated load - 1800 lbs in the center of a de 6" X 6" surface
- Made in Canada in our workshops
- Maximum leg height: 24"
- Options :
- Many sizes, heights, shapes and accessories available.
- Surface can be fireproofed for added safety.



STAGE RISER MD5012

STANDARD UNIT WEIGHTS AND SIZES

● 2' X 4'	0,61 m X 1,22 m	57 lb / 26 kg	● 3' X 8'	0,92 m X 2,44 m	130 lb / 59 kg
● 2' X 6'	0,61 m X 1,83 m	80 lb / 36 kg	● 4' X 4'	1,22 m X 1,22 m	91 lb / 41 kg
● 2' X 8'	0,61 m X 2,44 m	100 lb / 46 kg	● 4' X 6'	1,22 m X 1,83 m	126 lb / 57 kg
● 3' X 4'	0,92 m X 1,22 m	75 lb / 34 kg	● 4' X 8'	1,22 m X 2,44 m	161 lb / 73 kg
● 3' X 6'	0,92 m X 1,83 m	103 lb / 47 kg			

Note: Custom-made sizes available on request.

ACCESSORIES



An assortment of accessories is also available:

Stairs, ramps, trolleys, spiders, guardrails, stage skirts, chair bumpers, wheel adapters, etc.

