

SCAPIN

STAGE RISERS



SHOWSDT
Scene Design & Technology

STAGE RISER SCAPIN

SHOWSDT's Scapin riser is one of the most durable risers on the market, thanks to quality components such as aluminum extrusion and a 1" (24mm) birch plywood top. It can be used both indoors and outdoors.

The Scapin is modular, with its Dual Lock attachment system and different formats, it can be used to create stage structures, multi-level bleachers, podiums etc. (round stage available with this model).

In its standard version, it comes with four round aluminum legs with protective underlays, and a load capacity of 100 Lbs per square foot. It can also be fitted with accessories. (Stairs, leveling pads, handrails, carts, railings, stage skirts and fasteners, chair bumpers, wheel adapters, etc.).

ADVANTAGES :

Flexibility: The stage risers are held together with a Dual Lock fastening system to create a uniform surface. Installation is made easy by using a single hexagonal key to tighten the legs and connect the Dual Lock connectors.

Space saver: Each unit is only 4 inches thick (100 mm) allowing for easy storage in tight spaces. Maximize your storage space with our easy to handle transport and storage trolley.

Durability: Should a Dual Lock fastener, a leg mounting bracket or even an extruded section become damaged, any element can be unbolted from the platform and replaced by a new part without having to change the whole unit.

Modularity: The configuration possibilities are almost limitless. The Scapin can adapt to all your configuration needs.

Reliability: The simple and solid concept of the Scapin stage riser is covered by a first rate one-year warranty against manufacturing defects.

The Standard configuration comes with:

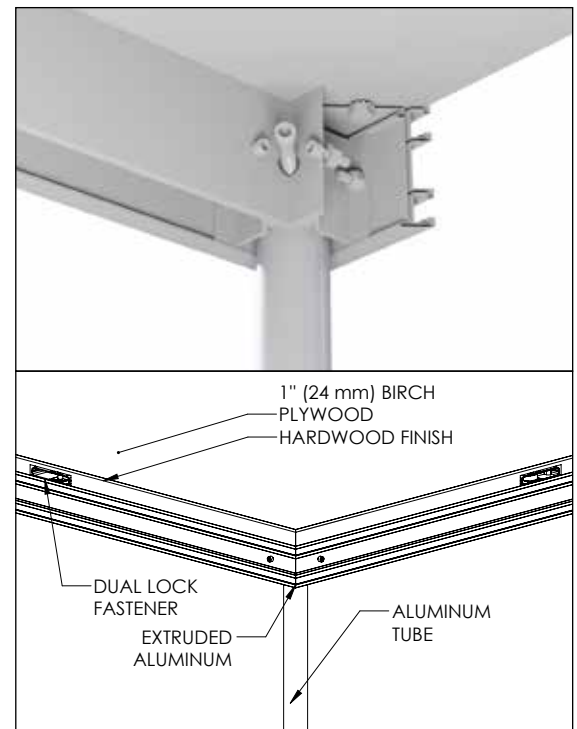

FEATURES

- Extruded aluminum alloy 6061-T6
- 1" (24 mm) birch plywood
- Can support a load of 100 lbs/sq ft
- Made in Canada in our workshops

Options :

- Custom-made: We can manufacture products of many shapes and sizes.
- Surface can be fireproofed for extra safety.
- Many finishes and colours available on request.



Dual Lock



STAGE RISER SCAPIN

STANDARD UNIT WEIGHTS AND SIZES

● 2' X 4'	0,61 m X 1,22 m	48lb / 22kg	● 3' X 8'	0,92 m X 2,44 m	110lb / 50kg
● 2' X 6'	0,61 m X 1,83 m	63lb / 29kg	● 4' X 4'	1,22 m X 1,22 m	77lb / 35kg
● 2' X 8'	0,61 m X 2,44 m	81lb / 37kg	● 4' X 6'	1,22 m X 1,83 m	107lb / 49kg
● 3' X 4'	0,92 m X 1,22 m	63lb / 29kg	● 4' X 8'	1,22 m X 2,44 m	135lb / 61kg
● 3' X 6'	0,92 m X 1,83 m	84lb / 38kg			

Note: Custom-made sizes available on request.

ACCESSORIES



An assortment of accessories is also available:

Stairs, ramps, trolleys, spiders, guardrails, stage skirts, chair bumpers, wheel adapters, etc.