

STAGING ACCESSORIES

MOVE & STORE CARTS

Move and store as many as 6 **SHOWSDT** at a time. Move & Store Carts move easily down hallways, around corners, and over thresholds. If you have to go up or down a stairway, two people can easily carry the decks separately.

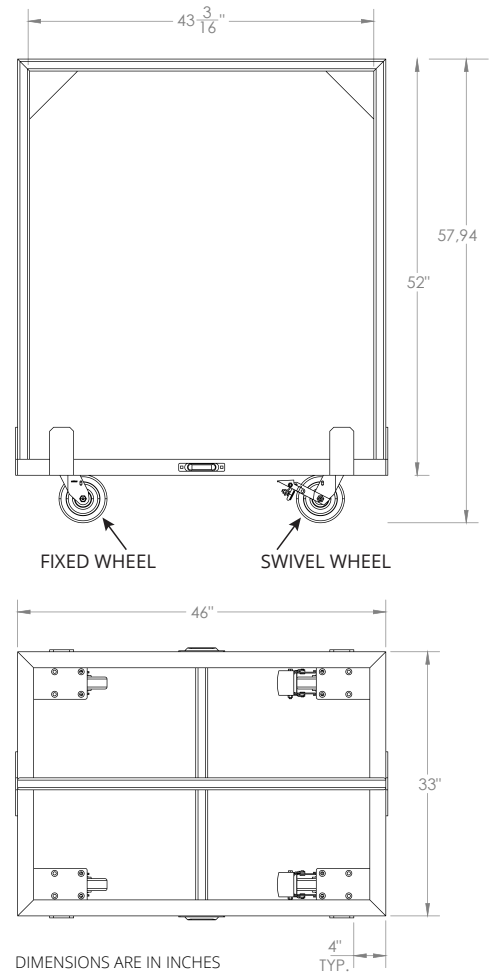

The Standard configuration comes with:

FEATURES

- 4 casters (2 with brakes, 2 without brakes)
- Easy setup and tear-down
- Can be set up by one person, no tools required
- Compatible with 4'x8' or others platform sizes
- Provides storage for 6 platforms